

CRIMSON GLEN

DOYLESTOWN TOWNSHIP, BUCKS COUNTY, PA

SERENITY MODEL SPECIFICATIONS

AVAILABLE ON LOTS #2, #3, #4



MAR-MAR CUSTOM HOMES

... UTMOST INTEGRITY IN CONSTRUCTION AND DESIGN

S T R U C T U R A L F E A T U R E S



- ✓ Fully Finished 2 Story Home plus Finished Basement
 - 5 Bedrooms (Owner's Suite Balcony); 6 Full Baths; 2 Half Baths
 - 2-Story Foyer; 2-Story Great Room
 - Grand Conservatory
 - 4-Car Garage
 - Chef's Kitchen with Double Island
 - Sunroom
 - 2nd Floor Laundry Room
 - Fully Finished Basement includes Custom Bar, Fireplace, Living Lounge, Billiards Room, Game Room, Flex Room (Nanny/In-Law/Gym), & Full Bathroom
 - ...and of course...Further Customization Available upon Request
- ✓ 10' First Floor Ceiling Height
- ✓ 9' Second Floor Ceiling Height
- ✓ 10' Basement Height with 10" Thick Monolithic Poured Concrete Walls
- ✓ TUFF-N-DRI 30-year Waterproofing System by Tremco Barrier Solutions
- ✓ Walk Up or out Basement with Sliding Door for Convenient Rear-Yard Access
- ✓ Underground Utilities, Well (Lot #4), Public Water (Lots #2 & #3). Septic and Propane
- ✓ Structural Steel I-Beam Construction
- ✓ Stick Framed Roof Construction
- ✓ Wood-frame 16" on Center Construction
- ✓ Engineered I-Joist Flooring System
- ✓ Sump Pit with Sump Pump in Basement - with Perimeter Under-Slab Drain

R O O F I N G & E X T E R I O R

- ✓ Weatherproof House-wrap - Tyvek water resistant barrier and rain barrier
- ✓ Spray Foam Insulation
 - R21 on all stud walls of living areas exposed to outside elements
 - R49 on all ceiling areas exposed to the roof
- ✓ Choice of Beautifully-Designed Stone / Brick Veneer and James Hardie Cement Board Elevations offered in a variety of Styles and Colors
 - Stone on Foundation - Front, Sides and Back *
 - Exterior Stone-Faced Chimney on Fireplace *
- ✓ Welcoming Front Porch Addition Options**
- ✓ Standing Seam Roofing as shown on Elevation
- ✓ Shutters Non-Operable Composite
- ✓ Advanced Polymeric Composite (APC) Windows, Trim Surrounds Throughout
- ✓ Vinyl-Coated Aluminum Soffits on Eaves and Overhangs
- ✓ Fascia & Porch Beam Wraps
- ✓ GAF Timberline 30-year Architectural Roof Shingles
- ✓ 6" Seamless Gutters & Downspouts (where applicable)
- ✓ 4' Wide Paver Walkway from Driveway to Main Entry Door**
- ✓ Porch Areas - Bluestone Topped and Stone Veneered Faced
- ✓ Professional Plant Package **

W I N D O W S

- ✓ Starmark EVO Advantage (in choice of exterior color options)
 - Double hung, locally manufactured, Advanced Polymeric Composite (APC) with low-E, argon-filled glass units, foam filled frame, grids between glass, and half screens



E X T E R I O R D O O R S

- ✓ Therma-Tru Classic-Craft 8'H with 12"H Transom
 - Double Main Entry, Mudroom, and Service Entry Doors* / **
 - Premium fiberglass in four wood grains or a smooth surface
- ✓ Masonite Solid-Core 8' Interior Doors 1st and 2nd Floors*
- ✓ Masonite Solid-Core 7' Interior Doors in Basement*
- ✓ HiMARK Elegante 8000 Sliding Patio Doors

G A R A G E D O O R S A N D O P E N E R S

- ✓ 4-Car Garage
- ✓ Clopay Coachman Series One or Four Insulated Garage Doors*
 - 9' x 9'H or 18' x 9'H
- ✓ LiftMaster 87504-267 (Single) or 8587 (Double) with Battery Backup & Wi-Fi Capability

F L O O R I N G & W A L L S

HARDWOOD

- ✓ Villa Borghese - French Oak -CARMINE, Width 8" T&G*
 - Foyer, Hallways, Dining, Study, Family Room, Kitchen, Sunroom, Butler's Pantry, Study Powder Room, First Floor Guest Suite, Owner's Suite

CERAMIC TILE FLOORING AND SHOWER WALLS

- ✓ Bathrooms
 - Owner's: Stanza White 12" x 24" Wall and Floor**
 - Secondary*: Balans 10" x 14" Wall; 12" x 24" Floor**
- ✓ Mudroom / Pantry / Mudroom Powder Room: Overall Cashmere 12" x 24" Floor**
- ✓ Laundry Room*: Balans 12" x 24" Floor**

LUXURY VINYL - BASEMENT

- ✓ Tarkett ProGen in all finished areas (excluding Bath)*

CARPET

- ✓ Mohawk Homefront II*
 - Secondary Bedrooms & Closets
 - Installed over 8 lb. ½" pad

K I T C H E N

FINISHES

- ✓ Custom Cabinetry by Colonial Craft Kitchens
- ✓ Countertops - Quartz on Perimeter and Island*
- ✓ Undermount or Farm Sink**
- ✓ Moen Sleek Faucet (in choice of finish)**
- ✓ Insinkerator Evolution Garbage Disposal with Air Switch Control**
- ✓ Hardware - Top Knobs Brand - Hopewell Collection (or equivalent)
- ✓ Backsplash - \$12 sq.ft. Allowance



APPLIANCES**

- ✓ 48" Wolf Gas Rangetop
- ✓ 48" Best Hood Vent Insert
- ✓ 30" Wolf Double Oven
- ✓ 42" Sub-Zero Refrigerator
- ✓ Bosch 300 Series, Fully Integrated Panel Ready Dishwasher
- ✓ 24" Wolf Transitional Drawer Microwave

B U T L E R ' S P A N T R Y

FINISHES

- ✓ Custom Cabinetry by Colonial Craft Kitchens
- ✓ Countertops - Quartz*/**
- ✓ Undermount Stainless Steel Sink**
- ✓ Moen Sleek Faucet (in choice of finish)**
- ✓ Hardware - Top Knobs Brand - Hopewell Collection (or equivalent)
- ✓ Backsplash - \$12 per sq. ft. Allowance

APPLIANCES**

- ✓ 24" XO Beverage or Wine Refrigerator

E L E V A T O R

- ✓ Three-Stop Accredited Elevator, Custom White Cab with Trim Detail
- ✓ \$35,000 Allowance

B A T H R O O M S

FINISHES

- ✓ Custom Cabinetry by Colonial Craft Kitchens
- ✓ Countertops - Quartz on Cabinetry and Shower Curbs*/**
- ✓ Sinks - Kohler Oval or Square Undermount **
- ✓ Pitched Wet-Bed Bases in all Shower Units with Tile Flooring & Walls to Ceiling
- ✓ Glass Shower Enclosures: Owner's, Basement, One (1) Location of Choice **
- ✓ Moisture Resistant Drywall & Fans Vented to Exterior
- ✓ Cement-Based Backer Board in Showers & Tub Areas
- ✓ Comfort Height Kohler 2-Piece Elongated Toilets Throughout **
- ✓ Moen Fixtures & Accessories: Owners - Colinet; Secondary - Cia (or equivalent) **
- ✓ Free-Standing Lucite Acrylic 67" Tub: Owner's Bathroom**
- ✓ Hardware - Top Knobs Brand - Hopewell Collection (or equivalent)



L A U N D R Y R O O M

FINISHES

- ✓ Custom Cabinetry by Colonial Craft Kitchens
- ✓ Quartz Countertops* with Undermount Sink - SILGRANIT patented surface **
- ✓ Kohler Simplice Faucet (in choice of finish) **
- ✓ Hardware - Top Knobs Brand - Hopewell Collection (or equivalent)

APPLIANCES**

- ✓ Electrolux Front Load Washer & Front Load Gas Steam Dryer

B A S E M E N T

FINISHES

- ✓ Bar Custom Cabinetry by Colonial Craft Kitchens
- ✓ Quartz Countertops with Undermount Stainless Steel Sink* / **
- ✓ Moen Align Faucet (in choice of finish)**
- ✓ Hardware - Top Knobs Brand - Hopewell Collection (or equivalent)

APPLIANCES

- ✓ 24" XO Beverage or Wine Refrigerator

F I R E P L A C E S

- ✓ Family Room - 42" Gas - Majestic Meridian Gas
 - Wood Mantle & Stone Surround/Hearth*
- ✓ Basement & Owner's Suite- choice of...
 - 32"/36" Majestic Meridian Gas with Wood Mantle and Stone Surround/Hearth*
 - 60" Allusion Platinum Electric Fireplace with Stone Surround and Mantle Shelf*

T R I M & I N T E R I O R F I N I S H E S



- ✓ 9" Baseboard Throughout
- ✓ Crown Molding - 2 Piece Throughout 1st and 2nd Floors
 - excluding secondary beds and baths
- ✓ Crown Molding - 1 Piece Throughout Basement including interior Trays - to be determined with Final Design and Placement of HVAC
- ✓ 3-1/2" Primed Wood Door and Window Casings
- ✓ Primed Wood Shoe Molding on Hard Surface Wood Floors
- ✓ Painted Solid Core Interior Doors *
- ✓ Wainscoting Wall Trim in the following locations: Foyer, Staircase, Dining Room, Basement - Select Locations Determined with Final Design
- ✓ Custom Wall Trim: Ingelnook / Owner's Bedroom Passthrough
- ✓ Plank-Board in Tray Ceiling in Owner's Bedroom
- ✓ Coffered Ceilings in Family Room (2 story) and Dining Room
- ✓ Grand Staircase with Stained White Oak Treads, Stained Handrails, Painted White Risers, Painted White Stringers, Painted White Balusters (hardwood stain matched)**
- ✓ Interior Trim and Doors Painted Semi-Gloss, One Color Throughout
- ✓ Interior Walls & Ceiling Painted Throughout, White Plus One Custom Color*
- ✓ Pantry Closet to Receive Solid Stacked Shelving**
- ✓ Solid Shelf with Slide Bar in all Closets**
- ✓ Oil Rubbed Bronze Lever Hardware on Doors Throughout**

E L E C T R I C A L

- ✓ Recessed Lighting Throughout Main Living Spaces and Halls***
- ✓ Recessed Lighting in Bedrooms and Closets***
- ✓ Decora Switches & Outlets Throughout
- ✓ Ceiling Fans Boxes in all Bedrooms
- ✓ Cat 6 Network Cable
 - All Bedrooms, Family Room, Study, Basement and Mech Room (Qt. 1)
- ✓ HDMI Transfer Cable
 - All Bedrooms, Family Room, Study, Basement and Mech Room (Qt. 1)
- ✓ COAX Cable
 - All Bedrooms, Family Room, Study, Basement and Mech Room

L I G H T F I X T U R E S

- ✓ Allowance is \$10,000
- ✓ Fixtures Selected with Builder's Design Team
- ✓ All Fixtures are Builder Supplied
- ✓ Selections exceeding \$10,000 shall be billed to Owner as an extra
- ✓ Bulbs for Light Fixtures charged against the \$10,000 Allowance
- ✓ Installation of Fixtures is included
 - Large fixtures requiring more than a single hour of assembly and installation will be charged at electrician's hourly rate



S P E C I A L T Y A L L O W A N C E S

- ✓ \$5,000 Allowance for lighting: in-cabinet, under cabinet, toe-kick, feature, etc...
- ✓ \$2,500 Allowance for Vanity Mirrors
- ✓ \$1,500 Allowance for under-cabinet strip outlets
- ✓ \$1,500 Allowance for Phone Wiring / Jacks
- ✓ \$15,000 Allowance for Front Landscaping
 - Additional Landscaping and Hardscaping Customization Available
 - Priced per specific design and in coordination with Builder
- ✓ Note: Further Customization Available with Builder's Design Team for All Allowances

M E C H A N I C A L & O T H E R

- ✓ 10 Year Homebuyers Warranty
- ✓ Three (3) Multi-Zoned Hi-Efficiency Heating and Air Conditioning Units**
 - One (1) Steam Humidifier
- ✓ Programmable Thermostats with Wi-Fi Capability **
- ✓ Two (2) High Efficiency Water Heater -75 Gallon **
- ✓ 400 Amp Service**
- ✓ UL-Approved, Interconnected Smoke Detectors and Carbon Monoxide Detectors with Battery Backup on each Floor and in each Bedroom
- ✓ Waterproof GFCI electrical outlets in front and rear as required by code

A D D I T I O N A L N O T E S

- ✓ Pre-construction AV Pre-wire and prep and installation
 - Custom designed with our partner, AudioLab
 - Priced per specific design and in coordination with Builder
- ✓ Pre-construction Security System prep and installation
 - Custom designed with our partner BAI
 - Priced per specific design and in coordination with Builder
- ✓ Well, Septic, & Propane - Included with Lot Purchase where applicable
- ✓ Driveway provided by Builder
 - Includes excavation, stone, base and topcoat from entry to top of garage parking area: 12' wide plus parking area per elevation



* Options Available for Review with Builder's Design Team

** Further Customization Available with Builder's Design Team

***As Recommended - up to 75 included

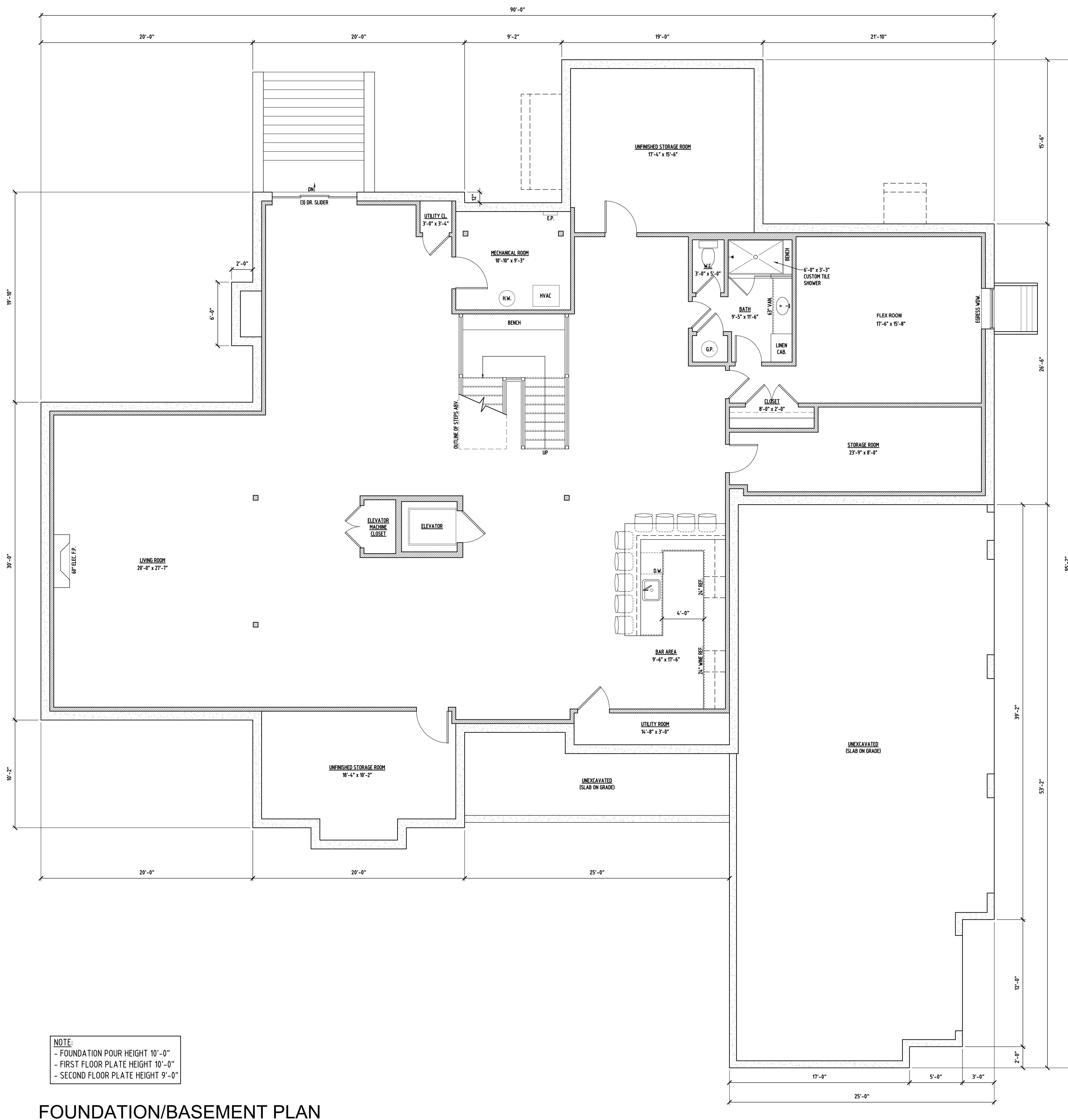

NOTE:
 - FOUNDATION POUR HEIGHT 10'-0"
 - FIRST FLOOR PLATE HEIGHT 10'-0"
 - SECOND FLOOR PLATE HEIGHT 9'-0"

FOUNDATION/BASEMENT PLAN

1/4"=1'-0"

GENERAL NOTE:
 THIS DOCUMENT IS FOR GRAPHIC PURPOSES ONLY. THE ARCHITECT AND ENGINEER SHALL BE RESPONSIBLE FOR CHECKING AND VERIFYING ALL DIMENSIONS, CONDITIONS, DIMENSIONS, ETC. BEFORE PROCEEDING WITH WORK.

Matthew V. Piotrowski
 Architect, LLC
 600 Louis Drive, Suite 103
 Warminster, PA 18974
 215.675.2099

CRIMSON GLEN
 SERENITY MODEL - LOT -
 DOYLESTOWN TWP, PA

Drawn By: JPA	
Checked By: MVP	
Date	Issue
10/6/22	Design Review
10/10/22	Design Review

2022227

DO NOT SCALE DRAWINGS
DD1

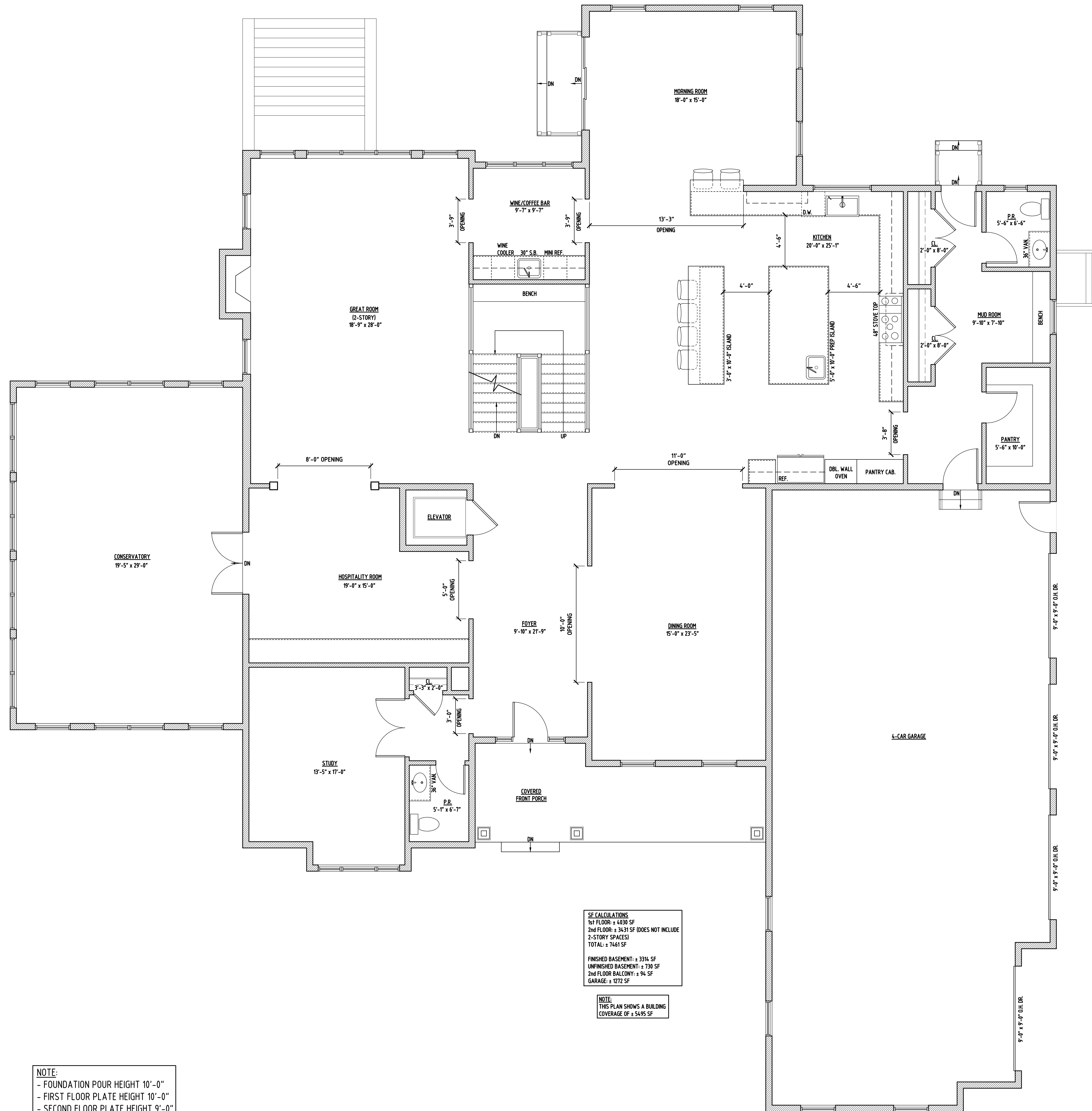

NOTE:
 - FOUNDATION POUR HEIGHT 10'-0"
 - FIRST FLOOR PLATE HEIGHT 10'-0"
 - SECOND FLOOR PLATE HEIGHT 9'-0"

SE CALCULATIONS
 1st FLOOR: ± 4930 SF
 2nd FLOOR: ± 3431 SF (DOES NOT INCLUDE 2-STORY SPACES)
 TOTAL: ± 7461 SF
 FINISHED BASEMENT: ± 334 SF
 UNFINISHED BASEMENT: ± 730 SF
 2nd FLOOR BALCONY: ± 94 SF
 GARAGE: ± 1272 SF

NOTE:
 THIS PLAN SHOWS A BUILDING
 COVERAGE OF ± 5495 SF

FIRST FLOOR PLAN
 1/4"=1'-0"

GENERAL NOTE:
 THIS DOCUMENT IS FOR GRAPHIC PURPOSES ONLY. THE ARCHITECT AND ENGINEER SHALL BE RESPONSIBLE FOR CHECKING AND VERIFYING ALL DIMENSIONS, CONDITIONS, DIMENSIONS, ETC. BEFORE PROCEEDING WITH WORK.

Matthew V. Piotrowski
 Architect, LLC
 600 Louis Drive, Suite 103
 Warminster, PA 18974
 215.675.2099

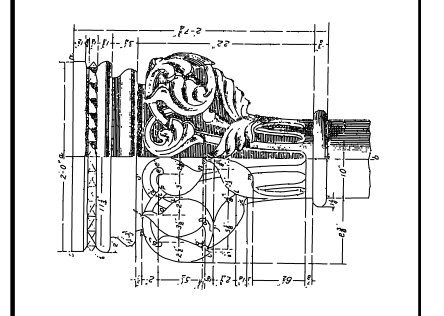

CRIMSON GLEN
 SERENITY MODEL - LOT -
 DOYLESTOWN TWP, PA

Drawn By: JPA
 Checked By: MVP
 Date Issue
 10/6/22 Design Review
 10/10/22 Design Review

2022227

DO NOT SCALE DRAWINGS

DD2



NOTE:
 - FOUNDATION POUR HEIGHT 10'-0"
 - FIRST FLOOR PLATE HEIGHT 10'-0"
 - SECOND FLOOR PLATE HEIGHT 9'-0"

SECOND FLOOR PLAN

1/4"=1'-0"

GENERAL NOTE:
 THIS DOCUMENT IS FOR GRAPHIC PURPOSES ONLY. THE ARCHITECT AND ENGINEER SHALL NOT BE RESPONSIBLE FOR CHECKING AND VERIFYING THE EXISTING CONDITIONS, DIMENSIONS, ETC. BEFORE PROCEEDING WITH WORK.

Matthew V. Piotrowski
 Architect, LLC
 600 Louis Drive, Suite 103
 Warminster, PA 18974
 215.675.2099

CRIMSON GLEN
 SERENITY MODEL - LOT -
 DOYLESTOWN TWP, PA

Drawn By:	JPA
Checked By:	MVP
Date	Issue
10/6/22	Design Review
10/10/22	Design Review

2022227

DO NOT SCALE DRAWINGS
DD3



FRONT ELEVATION

1/4"=1'-0"



RIGHT SIDE ELEVATION

1/4"=1'-0"

Optional Garage Door Configurations: 1 Double, 2 Single or 2 Double Doors

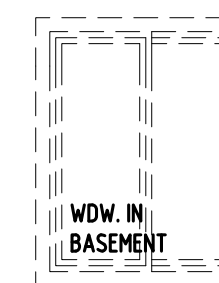

GENERAL NOTE:
THIS DOCUMENT IS FOR GRAPHIC PURPOSES ONLY. CONSULT WITH THE ARCHITECT FOR ALL TRADES AND OTHER TRADES SHALL BE RESPONSIBLE FOR CHECKING AND VERIFYING ALL DIMENSIONS, ETC. BEFORE PROCEEDING WITH WORK.

Matthew V. Piotrowski
Architect, LLC
600 Louis Drive, Suite 103
Warminster, PA 18974
215.675.2099

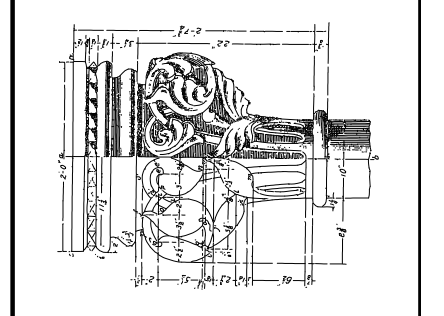

CRIMSON GLEN
SERENITY MODEL - LOT -
DOYLESTOWN TWP, PA

Drawn By: JPA	
Checked By: MVP	
Date	Issue
10/6/22	Design Review
10/10/22	Design Review

2022227

DO NOT SCALE DRAWINGS

DD4



REAR ELEVATION

1/4"=1'-0"



LEFT SIDE ELEVATION

1/4"=1'-0"

GENERAL NOTE:
THIS DOCUMENT IS FOR GRAPHIC PURPOSES ONLY. THE ARCHITECT AND OTHER TRADES SHALL BE RESPONSIBLE FOR CHECKING AND VERIFYING ALL DIMENSIONS, ETC. BEFORE PROCEEDING WITH WORK.

Matthew V. Piotrowski
Architect, LLC
600 Louis Drive, Suite 103
Warminster, PA 18974
215.675.2099

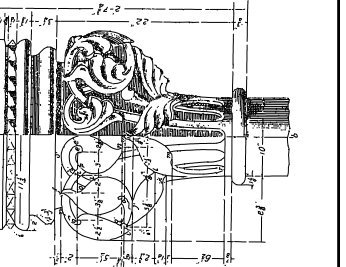

CRIMSON GLEN
SERENITY MODEL - LOT -
DOYLESTOWN TWP, PA

Drawn By: JPA
Checked By: MVP

Date	Issue
10/6/22	Design Review
10/10/22	Design Review

2022227

DO NOT SCALE DRAWINGS

DD5